

Nervous System Excitation Device

Gillis Patrick Flanagan

This invention relates to electromagnetic excitation of the nervous system of a mammal and pertains more particularly to a method and apparatus for exciting the nervous system of a person with electromagnetic waves that are capable of causing that person to become conscious of information conveyed by the electromagnetic waves.

It is an object of the present invention to provide a means of initiating controllable responses of the neuro senses without applying pressure waves or stress waves to the ears or bones. Another object of this invention is to provide a means of causing a person to receive an aural perception of the sound corresponding to the audio modulation of radio frequency electromagnetic waves that are coupled with the nervous system of the person. These and other objects of this invention will be understood from the following drawings and description of the invention, wherein:

Figure 1 is a schematic illustration of one form of the present nervous system excitation device.

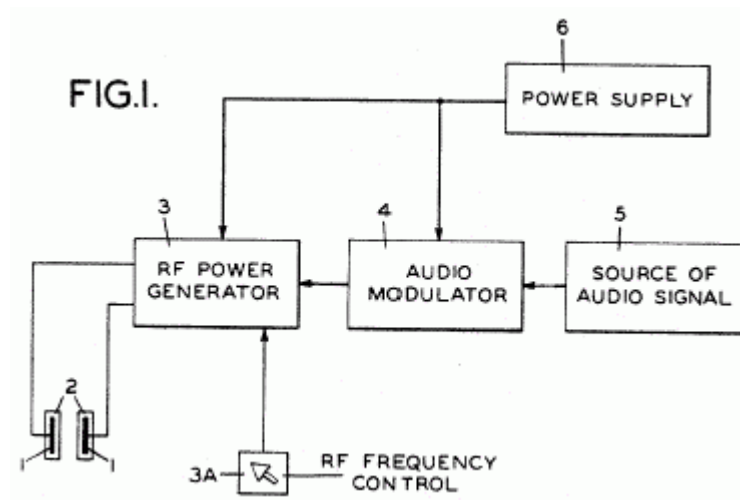

Figure 2 is a circuit diagram of one form of the present nervous system excitation device.

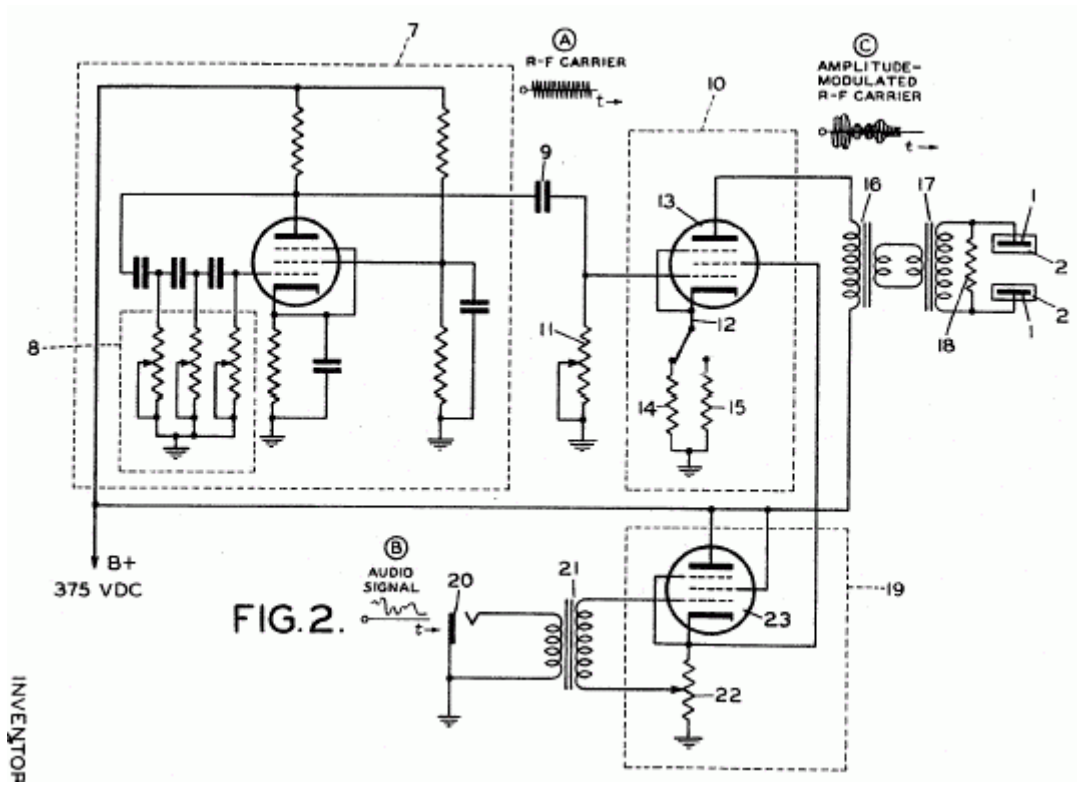

Figure 3 is a diagrammatic view illustrating one form of field generator adapted to be used with the device of Figure 1.

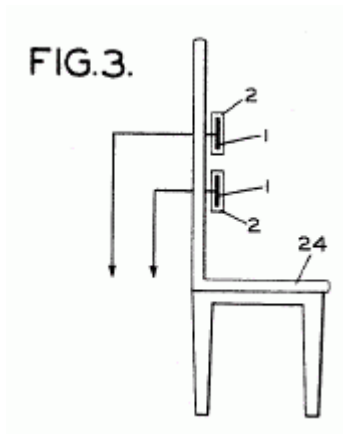

Figure 4 is a diagrammatic view illustrating another form of field generator adapted to be used with the device of Figure 1.



FIG.4.

The present invention involves the discovery that certain electromagnetic waves induce responses in the nervous systems of mammals. In human beings a response is produced when some or all of a person's nervous system is placed within a field of electromagnetic carrier waves of such a frequency, the nervous system is responsive to the modulation of the carrier waves. Each individual nervous system is at least somewhat selective in respect to the frequencies to which it is most responsive. A frequency to which the nervous system of a person is demonstratively responsive can be determined by varying the frequency of carrier waves that are modulated by an information signal, such as speech or music, and measuring the frequency of such waves that produce the sensation of hearing the sounds corresponding to the modulating signal.

In the method of the present invention, a response is initiated in the nervous system of a mammal by disposing at least a portion of that nervous system within a field of electromagnetic waves of a frequency above the aural range. In a preferred embodiment of this invention, at least a portion of the nervous system of a person is exposed to audio modulated electromagnetic waves having a radio frequency such that the person experiences the sensation of hearing, substantially free of distortion, the information which is conveyed by the audio modulation.

The present invention may be used as a hearing aid, as an aid to teaching speech to a person who was born deaf, as a means of communicating with persons in locations in which the noise level is high, as a device by which a person can listen to an audio signal that cannot be heard by others, etc.

As shown in Figure 1 of the drawing, in a preferred form of the invention, a field of electromagnetic waves is generated by a field generating means, such as a pair of electrodes 1. The electrodes 1 are preferably electrically insulated, for example by surrounding them with a suitable electrical insulating material 2, and are arranged to generate a field coupled with at least a portion of the nervous system of a person, for example by being placed near or along opposite sides of a person's head. The electrodes 1 can be placed in direct contact with the skin and the electrodes can be

placed on or near various portions of the body, such portions preferably being near the spinal cord.

The electrodes 1 are electrically connected to a source of modulated electromagnetic waves inclusive of a radio frequency power amplifier and variable frequency oscillator, indicated in box 4, a source of audio signal, indicated in box 5, and a power supply for the signal source, modulator and amplifier, indicated by box 6. The variable frequency oscillator 3 is preferably provided with a manual radio frequency control means, indicated by box 3a. Numerous forms of the components, indicated in boxes 3 to 6, that provide suitable power and a source of modulated electromagnetic waves are presently known and the known devices can be suitably used as long as they are arranged to produce a relatively high voltage output that has a radio frequency above the audio range and is capable of being modulated by an audio signal or other signal adapted to be conveyed by the modulation of electromagnetic waves of such a frequency.

The modulation can suitably be effected by means of either an amplitude or frequency modulation of such electromagnetic waves. These waves preferably have a frequency in the range of about 20 kilocycles per second to about 200 kilocycles per second. The output of the source of modulated electromagnetic waves is preferably at least about 1 watt where the field generator comprises a pair of insulated electrodes placed on the head of a person. The extent to which a person is aurally perceptive to the output supplied at a given wattage is materially increased when at least one of the electrodes is placed in electrical contact with the body of the person.

In a preferred mode of operating the apparatus shown in Figure 1, the electrodes 1 are placed on the sides of the head of a person. The source 5 of audio signal is actuated to produce an audio signal corresponding to sounds recognizable by that person, and source 3 of modulated electromagnetic waves is actuated to couple the waves with the nervous system of that person. When control 3A is adjusted so that the frequency of the modulated waves is a frequency to which his nervous system is particularly responsive, the person to whom the field of such waves is applied has the sensation of hearing the sounds corresponding to the audio signal substantially free of distortion.

In the circuit shown in Figure 2, a phase shift type of carrier oscillation, generally designated by dotted rectangle 7, with a frequency control, generally designated by rectangle 8, is arranged to produce electromagnetic waves, shown at A, a frequency ranging from about 20 to 200 kilocycles per second. The oscillator output is coupled through capacitor 9 to a radio frequency power amplifier, generally designated by a dotted rectangle 10. Potentiometer 11, which is connected between capacitor 9 and

ground, provides a means of adjusting the input to the amplifier. Switch 12, which is connected to the cathode of tube 13 of the amplifier, provides a means of switching between resistors 14 and 15 to vary the operating power characteristics of the tube.

The output of amplifier 10 is connected to transformer 16 which is coupled back-to-back with transformer 17. This arrangement of transformers provides an inductive load such that the amplifier yields a high voltage output is isolated from other components of the circuit. Resistor 18 connected across the output side of transformer 17 serves to reduce any dangerous voltage spikes which might be produced. The output side of transformer 17 is connected to a suitable field generator, which may comprise the electrodes 1 surrounded by insulating material 2.

The output of amplifier 10 is amplitude modulated by means of the modulator generally designated by dotted rectangle 19. A fluctuating electrical signal B, preferably of audio frequency, is applied to the modulator by means of input jack 20 and transformer 21. The output of the modulator varies the screen voltage of tube 13 of the amplifier so that the modulation envelope of the current oscillations C produced across the load of tube 13 correspond to the fluctuating signal B applied to the modulator.

Potentiometer 22 is connected to the cathode of tube 23 as the cathode resistor of tube 23. Potentiometer 22 is preferably adjusted so that the plate current of tube 13 of the amplifier so that the modulation envelope of the current oscillation C produced across the load of tube 13 correspond to the fluctuating signal B applied to the modulator.

Potentiometer 22 is connected to the cathode of tube 23 as the cathode resistor of tube 23. Potentiometer 22 is preferable adjusted so that the plate current of tube 13 is about half its normal maximum value. The fluctuating signal applied to modulator 19 is then adjusted to cause the plate current of tube 13 to vary between the maximum and minimum values so that a large current variation occurs in the load 16 of tube 13.

The apparatus shown in Figure 2 has been used to communicate speech and music to numerous persons including registered physicians. In these uses the electrodes 1, in the form of circular disc covered by a plastic insulation 2, were placed against the sides of the heads of the persons. When the electromagnetic waves were adjusted to a frequency to which persons having normal hearing were selectively responsive, none of these persons perceived any sensations of hearing or experienced any discomfort when no audio modulation was applied to the waves. When the waves were audio modulated with a speech or music signal, none of these persons experienced any discomfort, but they each had the sensation of listening to the

transmitted information and hearing it at least as clearly as they would hear such information from an audible transmitter. When the same apparatus was similarly employed on a person whose hearing had been damaged to an extent requiring a hearing aid to hear normal conversation, that person heard the audio signal (with this hearing aid disconnected) and heard music with a better fidelity than that obtainable with this hearing aid.

Figure 3 shows an arrangement for mounting the field generating means in a position such that a portion of a person's nervous system may be moved into and out of coupling with the field at the will of the person. In this arrangement, electrodes 1 surrounded by insulation 2 are mounted in vertical alignment along the back of a seating device, such as chair 24. When a person is seated and leaning back in the chair, portions of his nervous system are brought into coupling relationship with the field produced by electrodes 1.

Figure 4 shows an alternative arrangement of the field generating means. In this arrangement, inductive coil 25 is connected to the output of a suitable source of modulated electromagnetic waves and serves as a field generating means which is adapted to be placed around the head of a person.

It is to be understood that the above embodiments and examples have been presented for descriptive purposes and that, within the scope of the appended claims, the invention may be practiced otherwise than specifically illustrated and described.